

PRODUCT CODE:60.110.320.331

prefabase
Quick Build Solutions

Instructions and User Guide

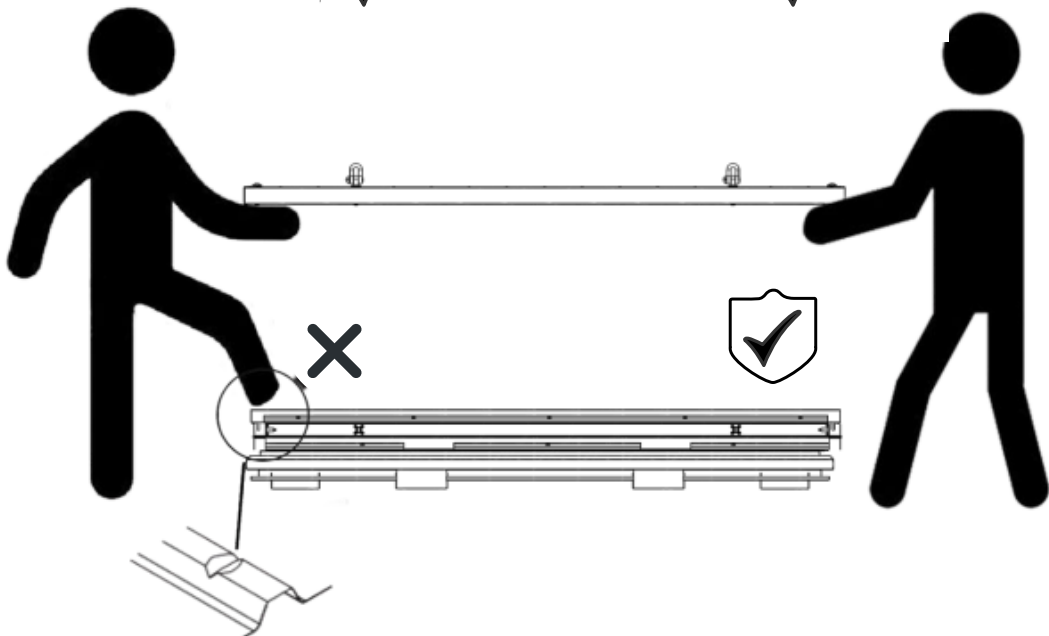
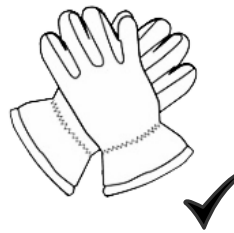
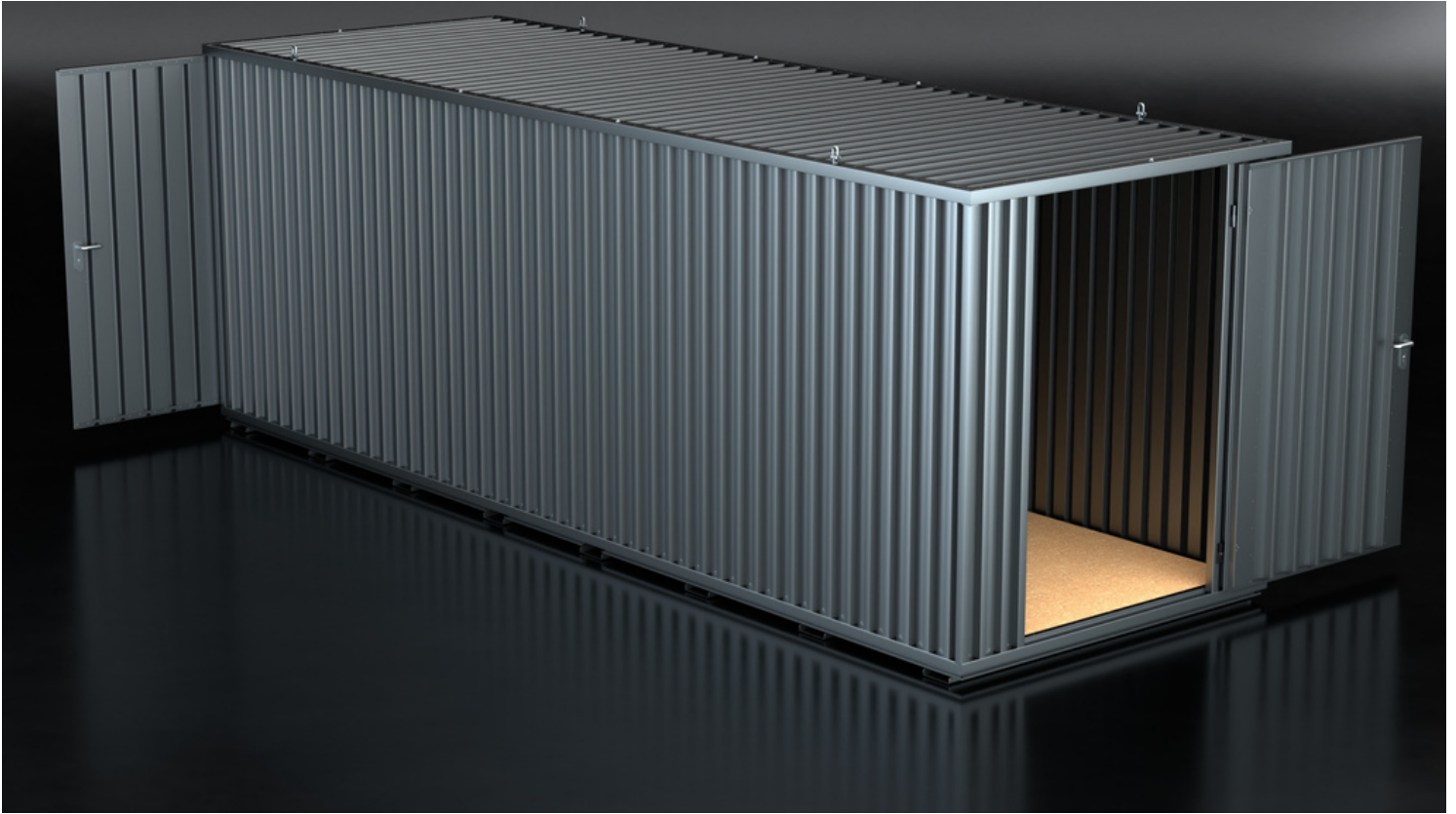

60.0110
1x

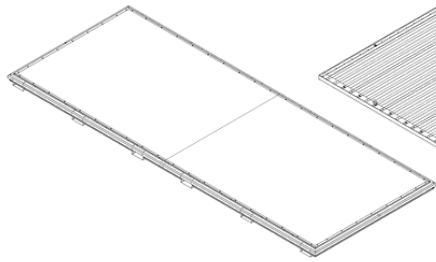

60.0510
1x

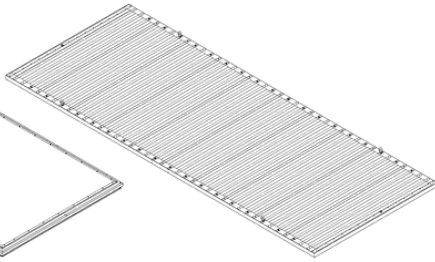

60.0410
2x

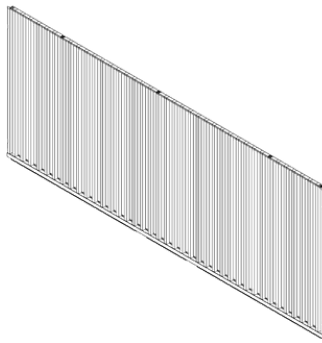

0320
1x



0330
1x



61.101
2x



14x

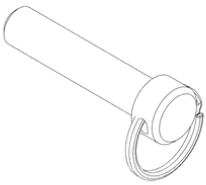

2x

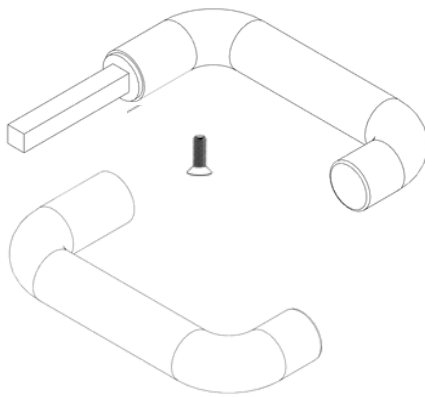

1x

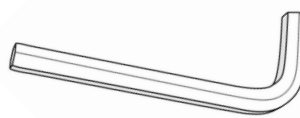

2x



1

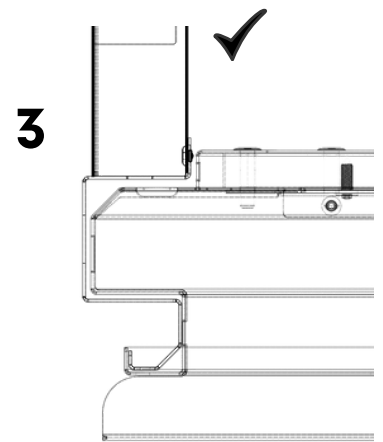
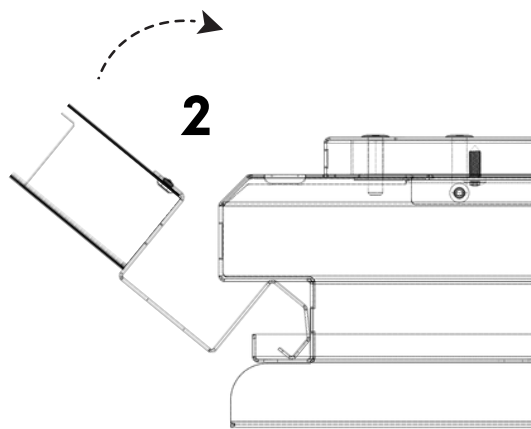
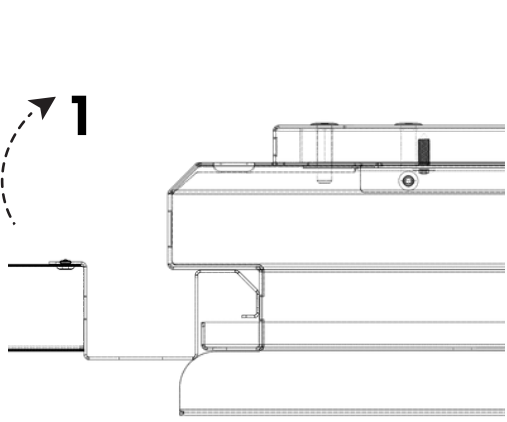
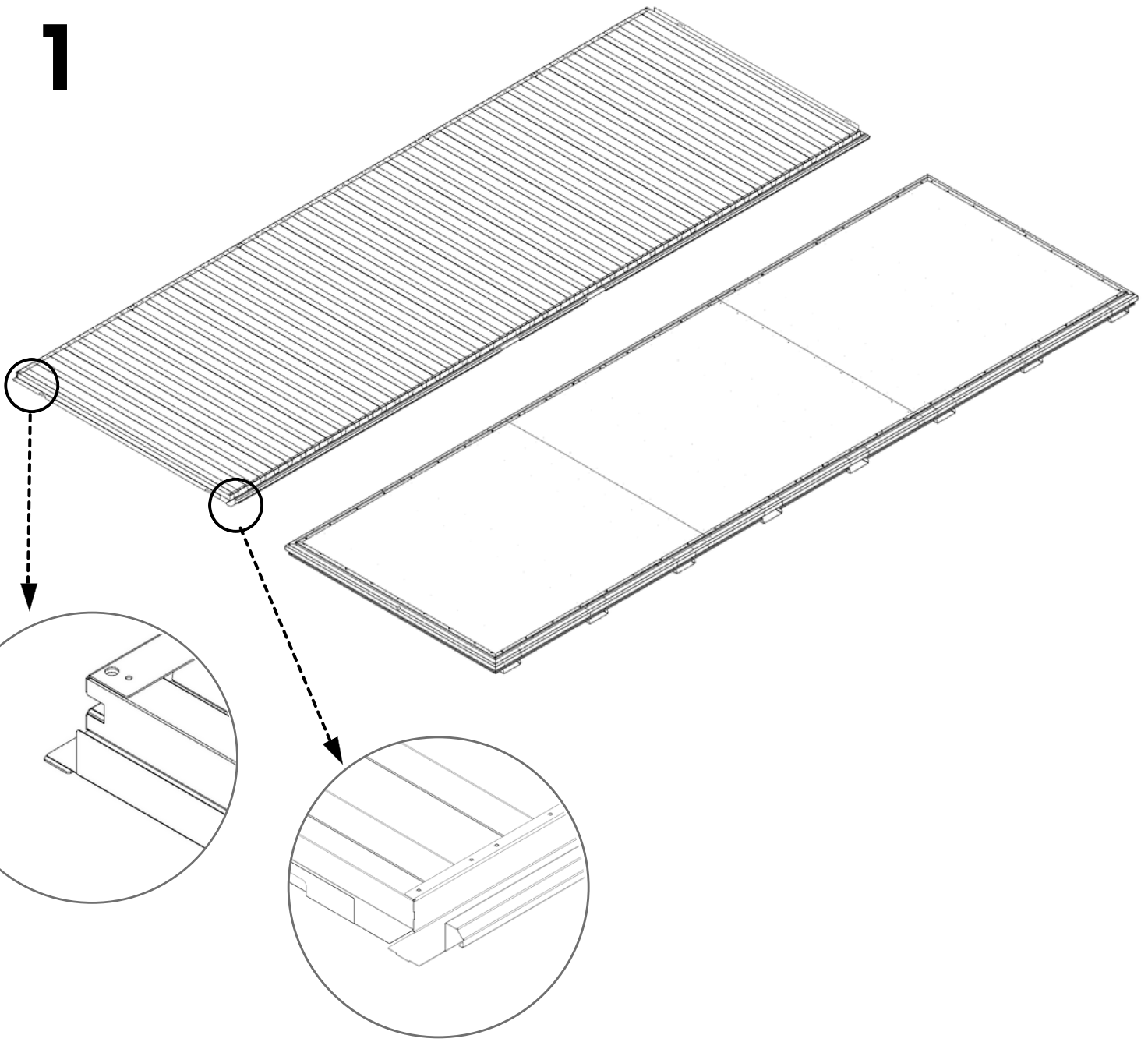

2

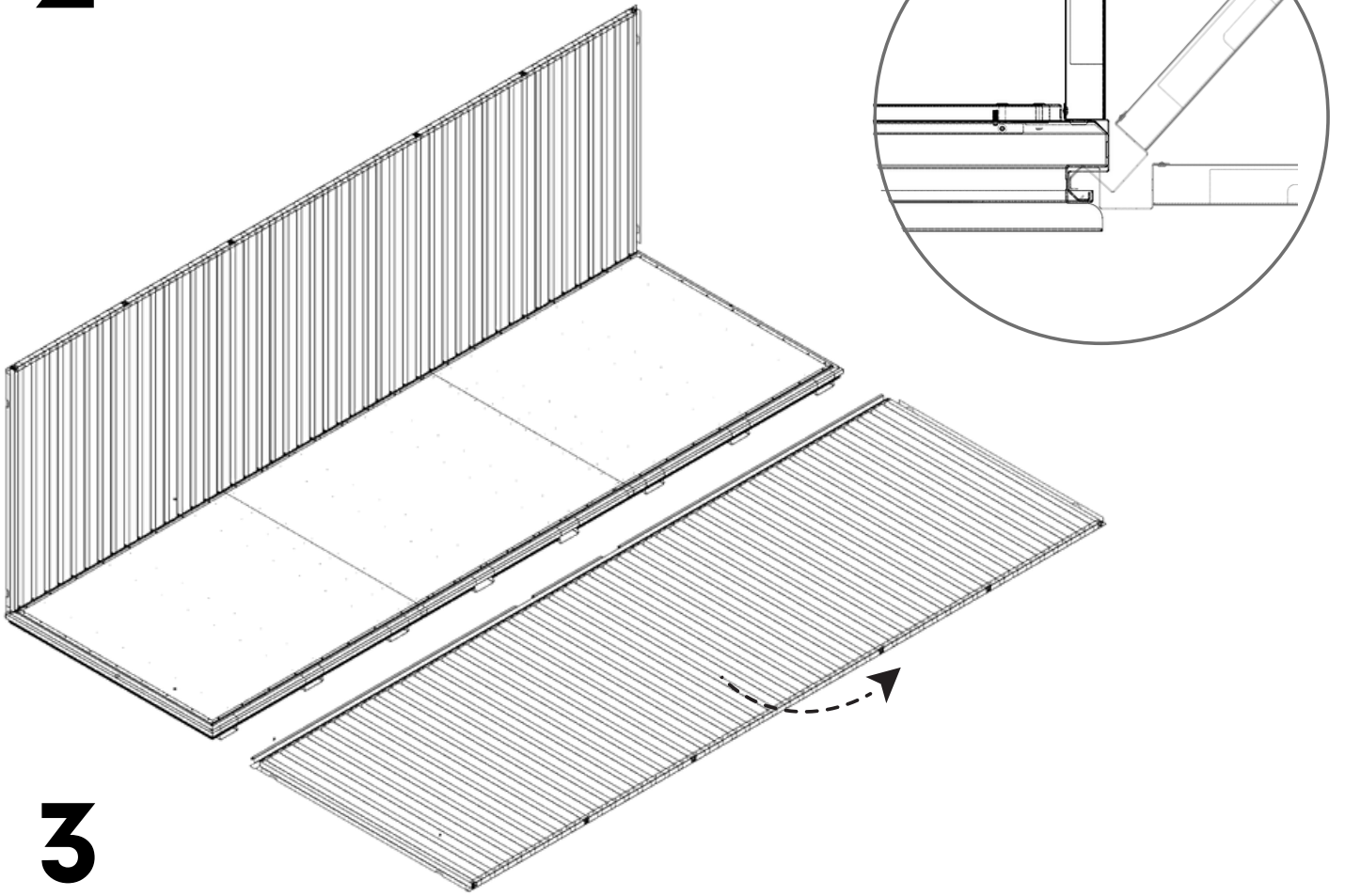

3

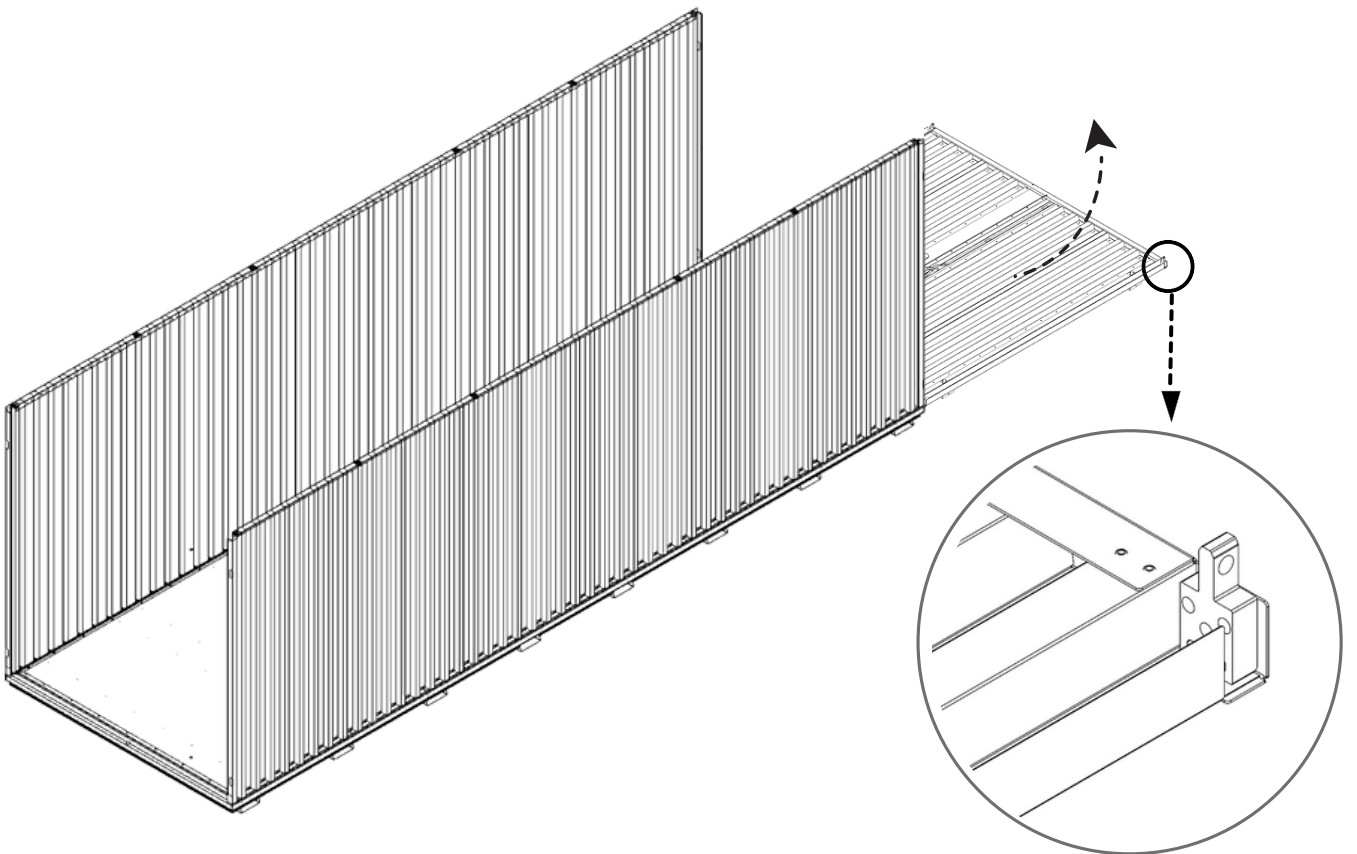

3.1

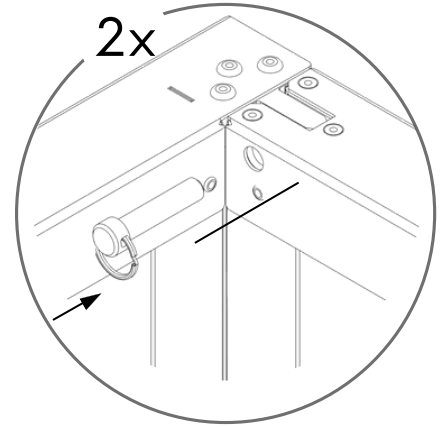
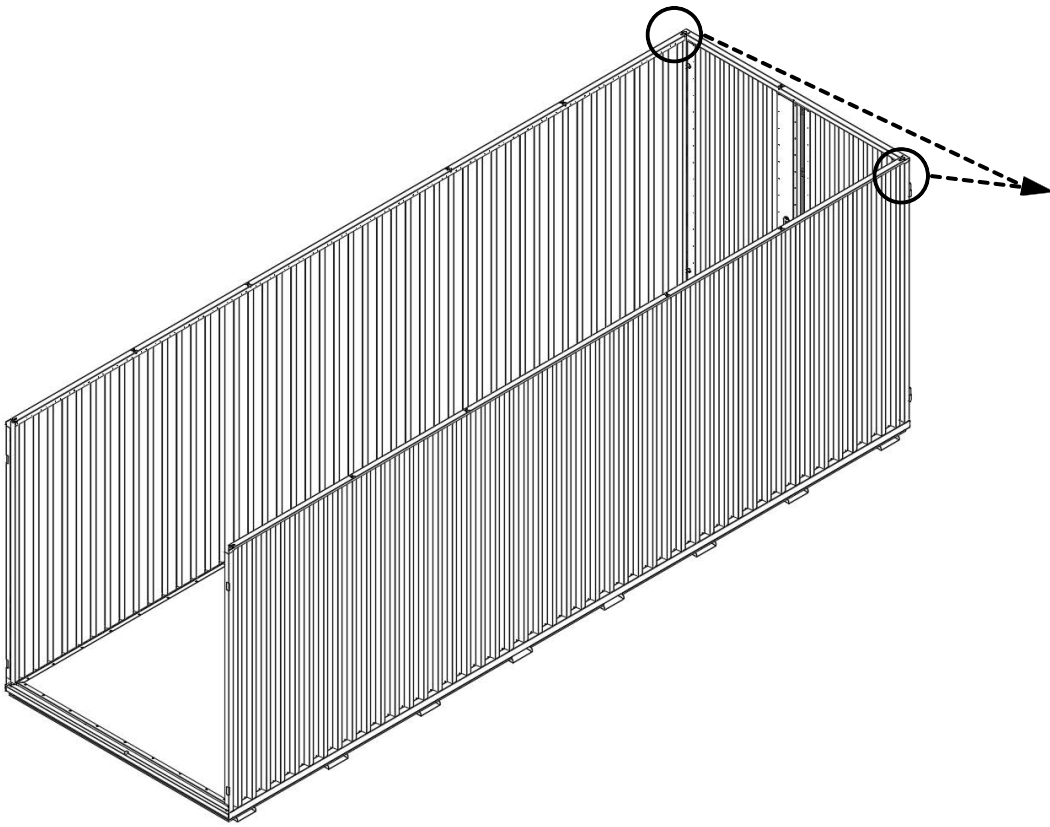



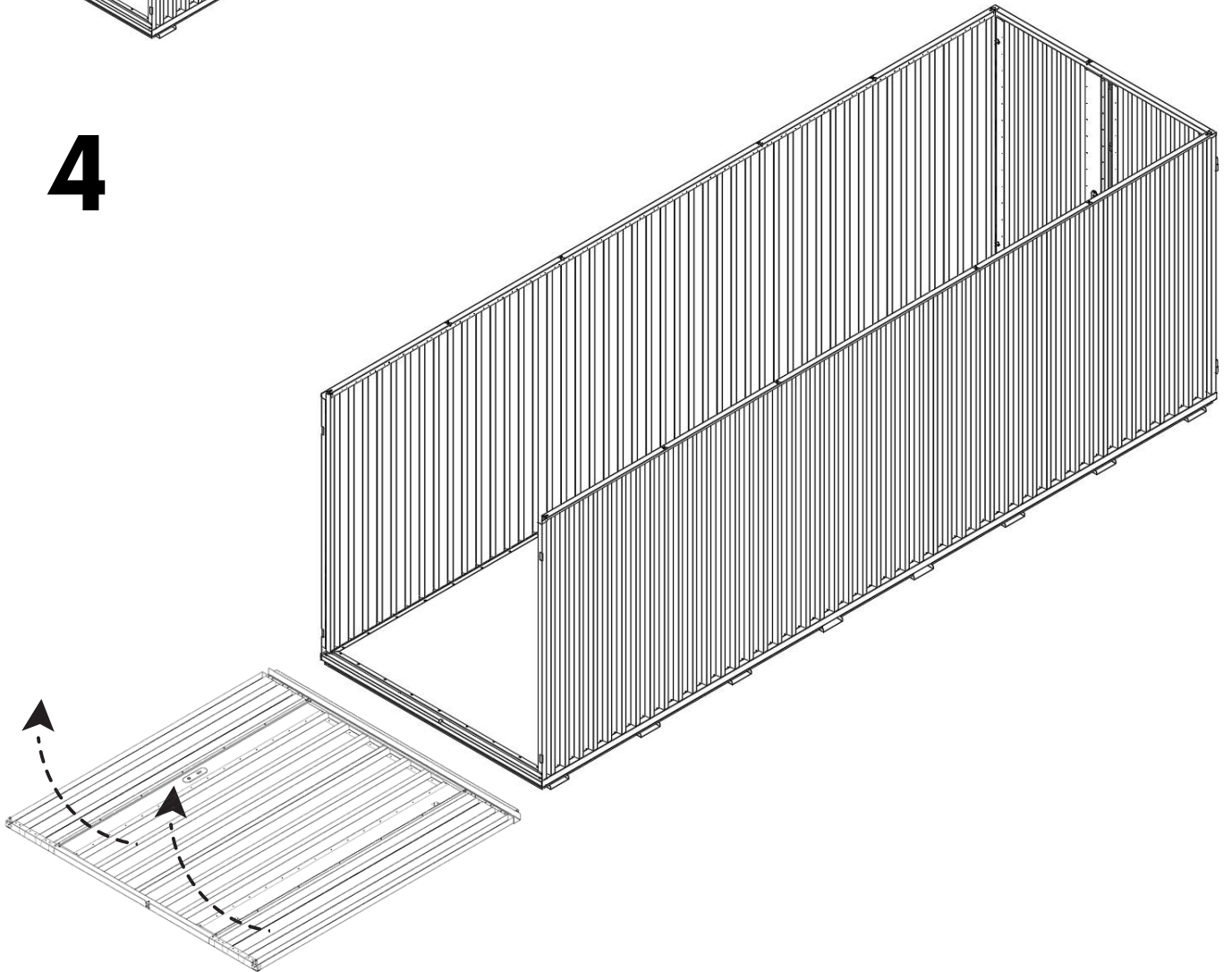



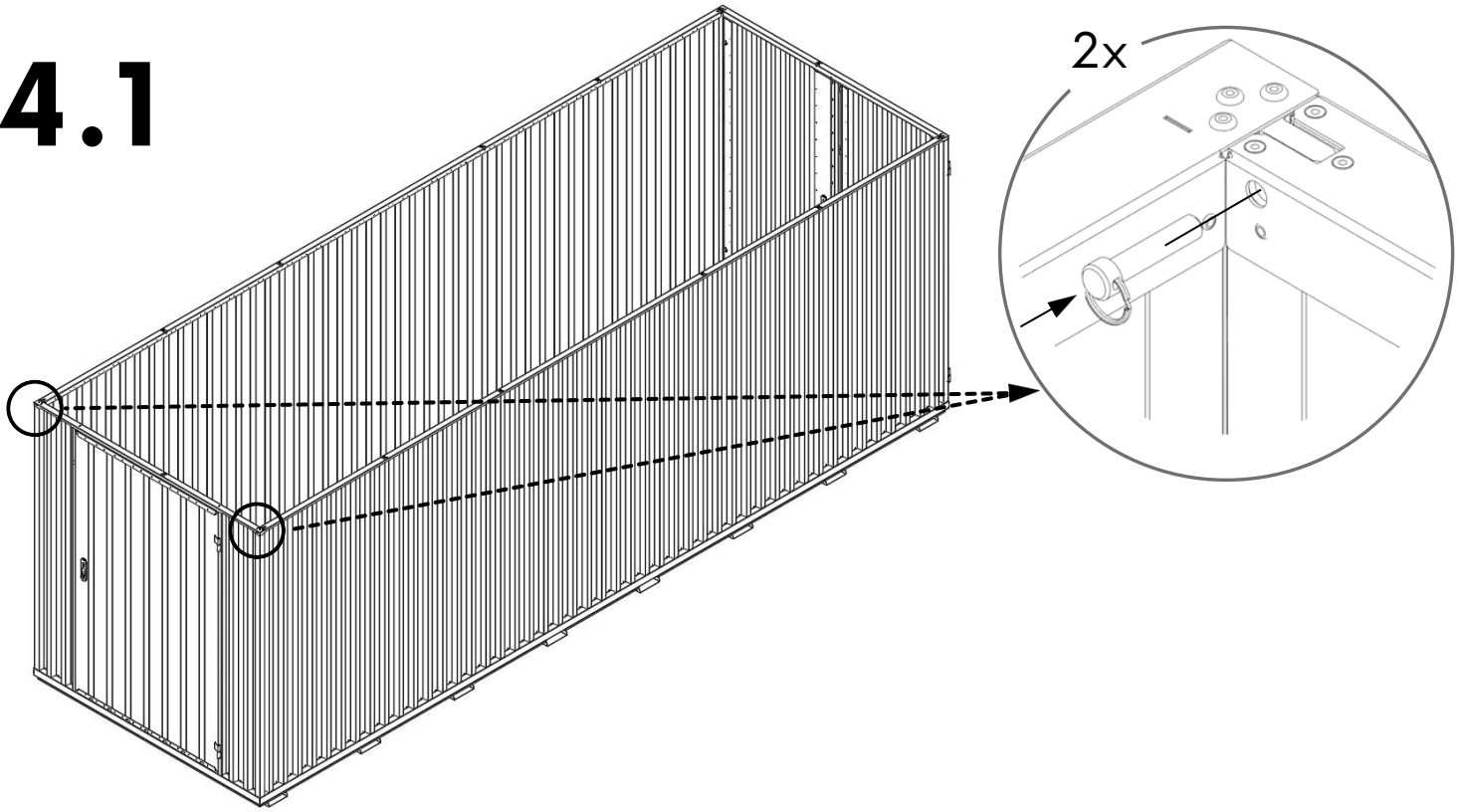

4



4.1



 602 KG	 1640 MM	Model Code: 60.110.320.331 Production Tracking Code:/X09.1.60.320.331  9001  14001  50001	 	
---	--	---	---	---

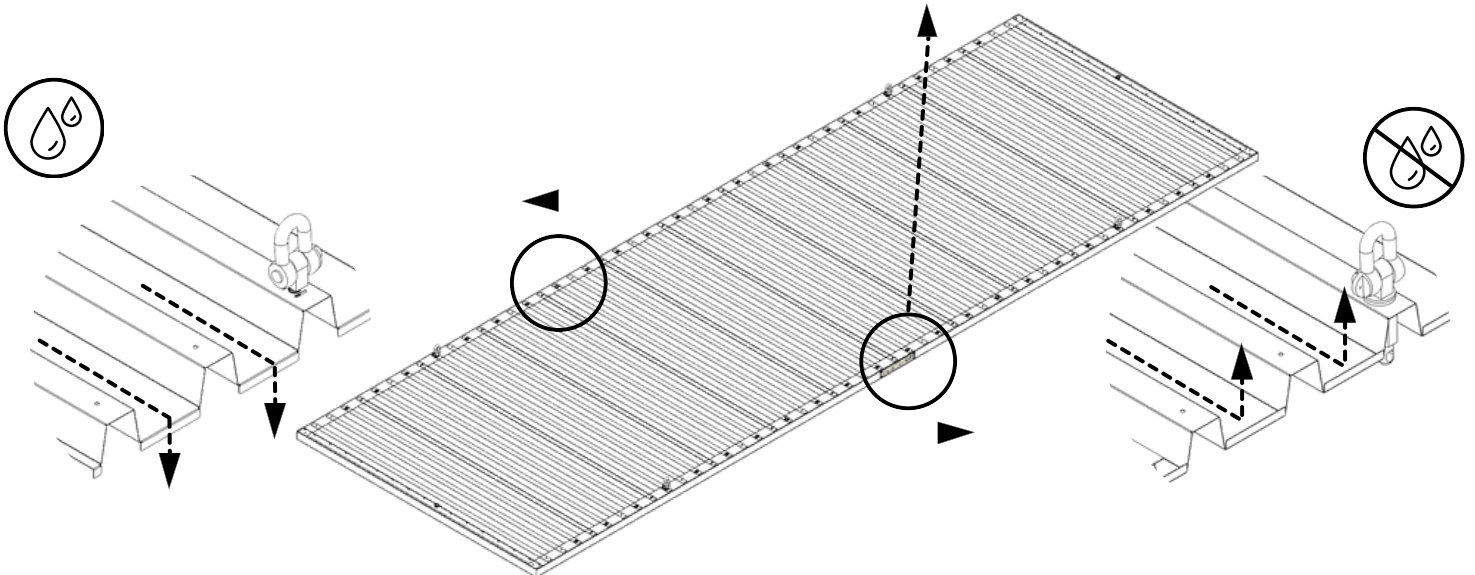

5

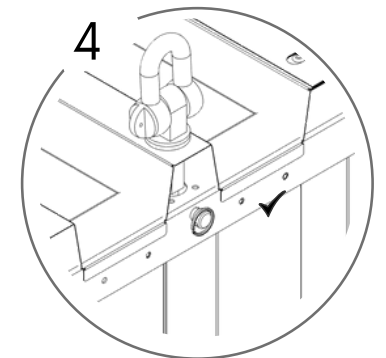
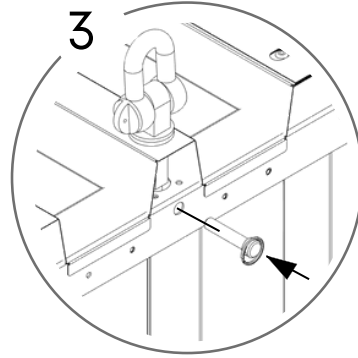
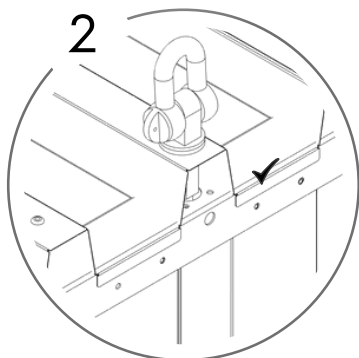
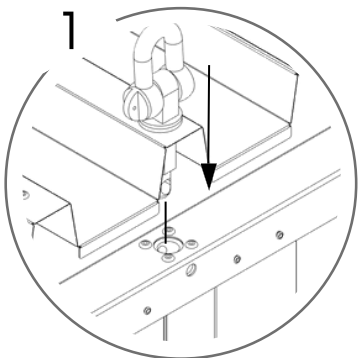
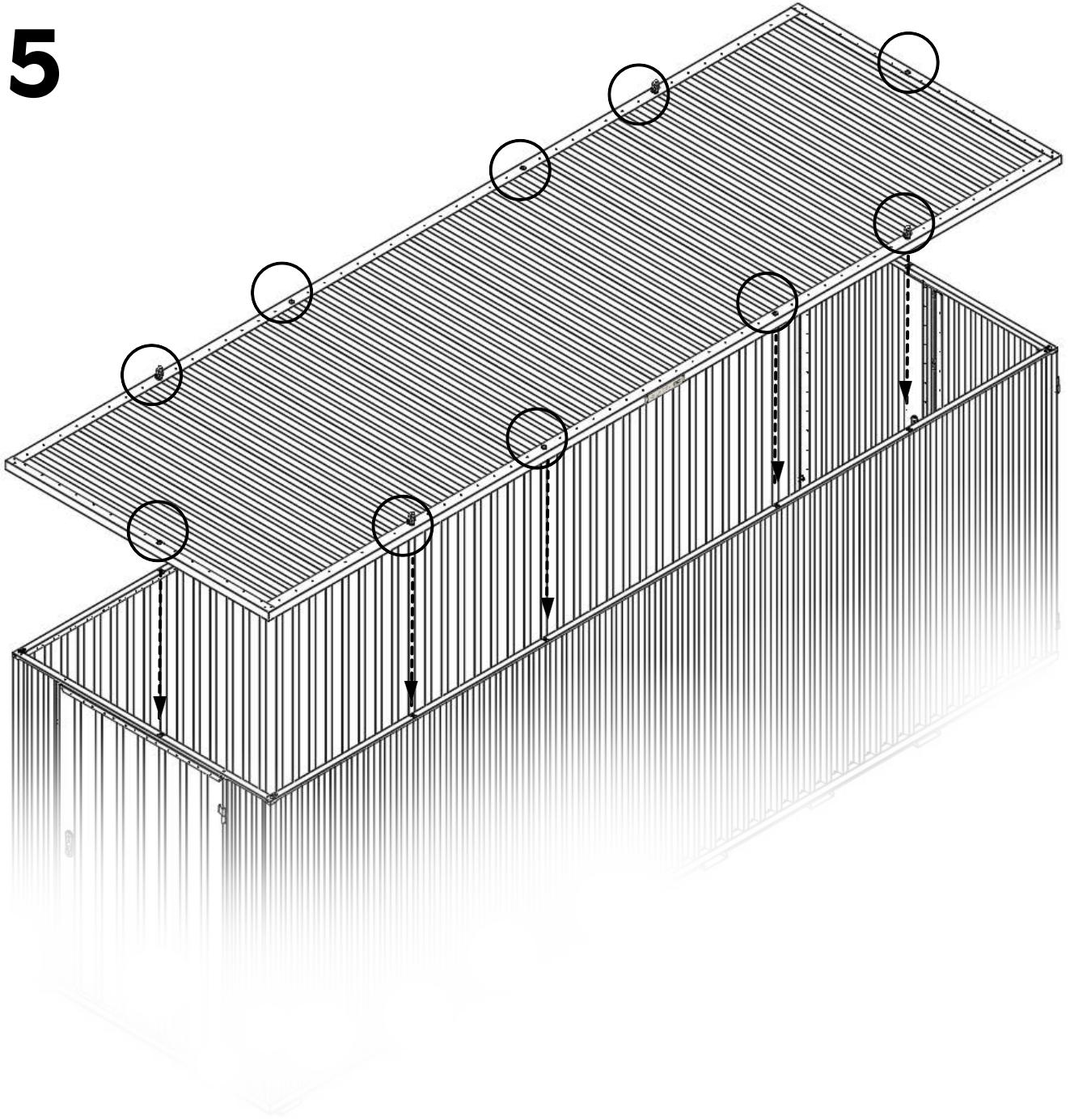

6

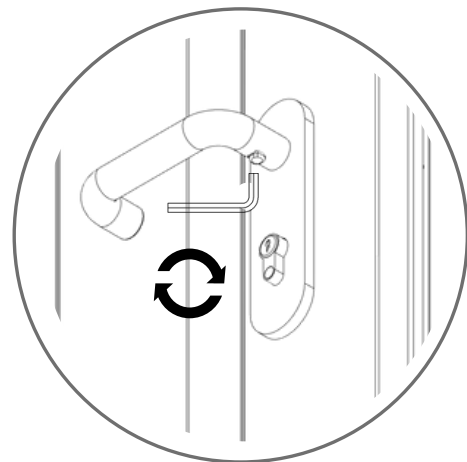
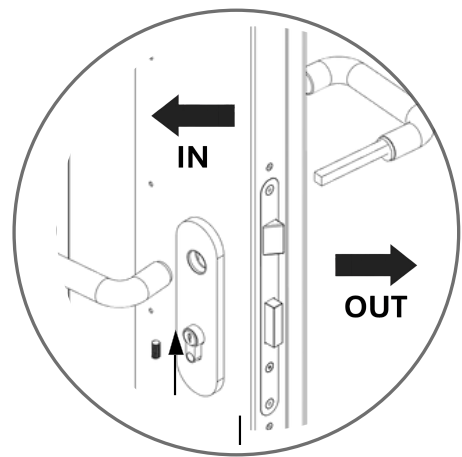
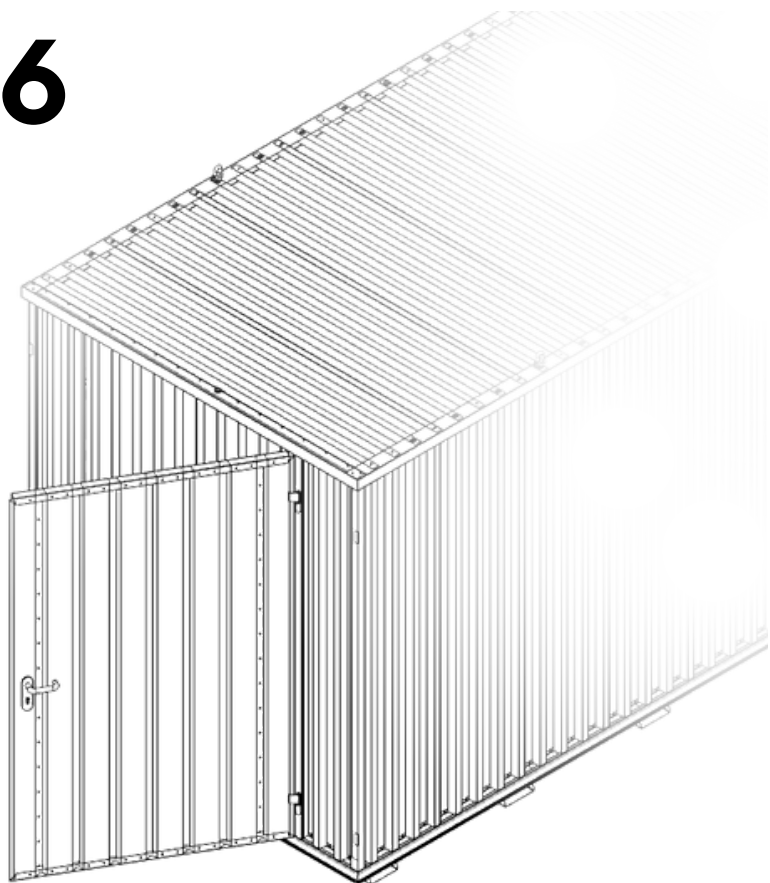

7

